



### Model Number

NBN4-F29-E2

### Features

- 4 mm non-flush
- 3-wire DC

## Technical Data

### General specifications

Switching element function	PNP	NO
Rated operating distance	$s_n$	4 mm
Installation		non-flush
Output polarity		DC
Assured operating distance	$s_a$	0 ... 3.24 mm
Reduction factor $r_{Al}$		0.4
Reduction factor $r_{Cu}$		0.3
Reduction factor $r_{304}$		0.7

### Nominal ratings

Operating voltage	$U_B$	4.75 ... 30 V DC
Switching frequency	$f$	0 ... 1000 Hz
Hysteresis	$H$	typ. 5 %
Reverse polarity protection		reverse polarity protected
Short-circuit protection		pulsing
Voltage drop	$U_d$	$\leq 3$ V
Operating current	$I_L$	0 ... 100 mA
Off-state current	$I_r$	0 ... 0.5 mA typ. 0.1 $\mu$ A at 25 °C
No-load supply current	$I_0$	$\leq 10$ mA
Time delay before availability	$t_v$	$\leq 5$ ms
Switching state indicator		LED, yellow

### Functional safety related parameters

MTTF <sub>d</sub>	1680 a
Mission Time (T <sub>M</sub> )	20 a
Diagnostic Coverage (DC)	0 %

### Ambient conditions

Ambient temperature	-25 ... 70 °C (-13 ... 158 °F)
Storage temperature	-40 ... 85 °C (-40 ... 185 °F)

### Mechanical specifications

Connection type	cable PVC , 2 m
Core cross-section	0.14 mm <sup>2</sup>
Housing material	PPS
Sensing face	PPS
Degree of protection	IP67

### Compliance with standards and directives

Standard conformity	
Standards	EN 60947-5-2:2007 IEC 60947-5-2:2007

### Approvals and certificates

UL approval	cULus Listed, General Purpose
CSA approval	cCSAus Listed, General Purpose
CCC approval	CCC approval / marking not required for products rated $\leq 36$ V

## Dimensions

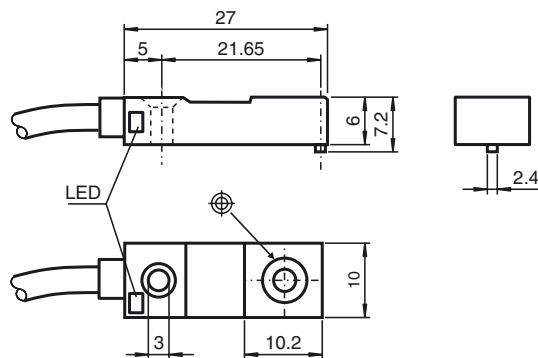

## Electrical Connection

